

CHEMICAL PUMPS SINCE 1992

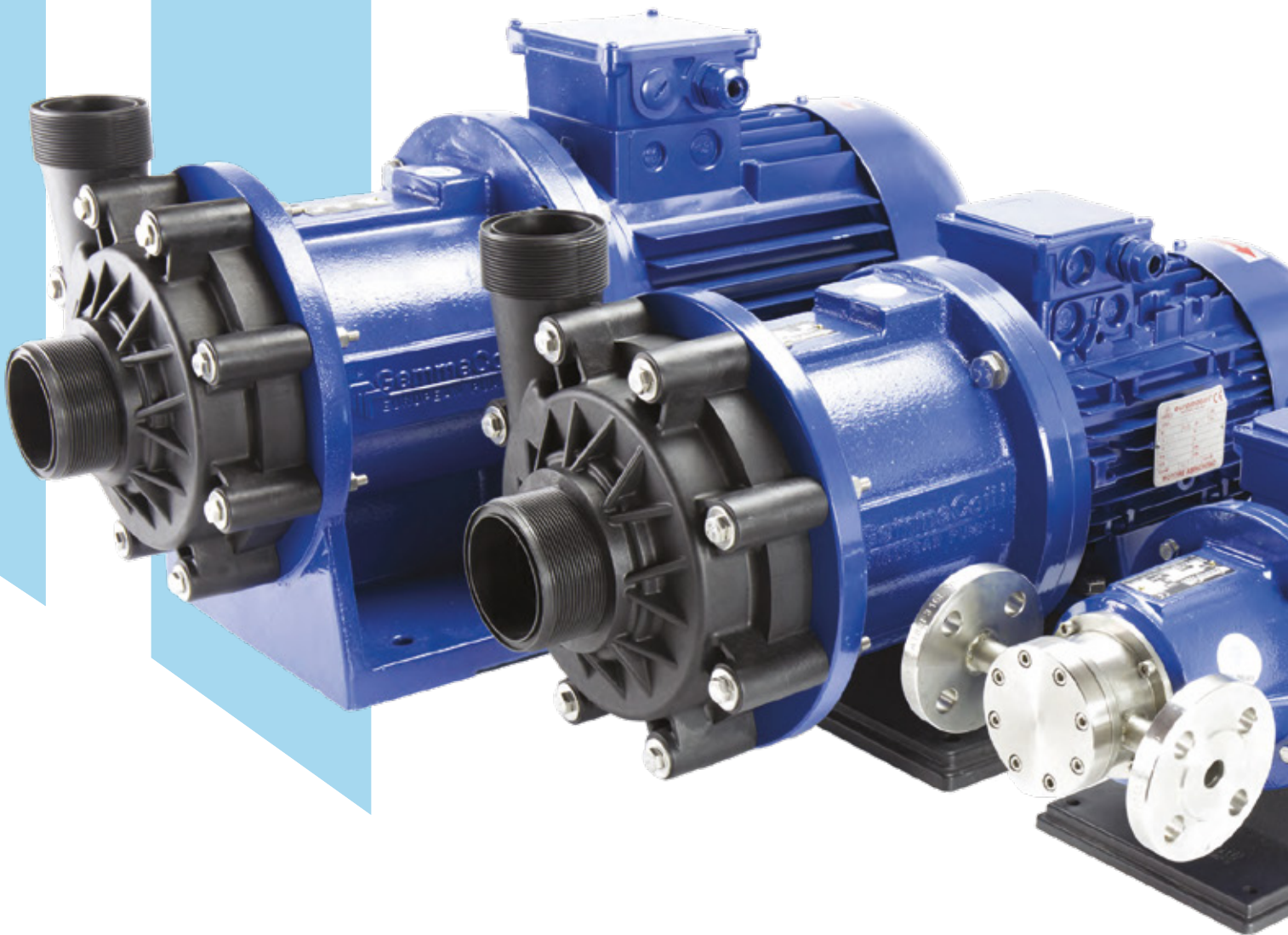

ATEX PUMPS PP/PVDF



For applications in potentially explosive atmospheres GemmeCotti offers ATEX certified pumps.

ATEX pumps made of thermoplastic material polypropylene (PP) or PVDF are suitable to be used in potentially explosive atmospheres classified zone 2 II 3G c Tx.

All our ATEX pumps comply with the technical and safety requirements of ATEX Directive 2014/34/EU.

Pump model EM-C PP/PVDF - only for ATEX zone 2
(See pump model HTM PP/PVDF page 12)



Pump model EM-T PP/PVDF - only for ATEX zone 2
(See pump model HTT page 28)



Pump model EM-P PP/PVDF - only for ATEX zone 2
(See pump model HPP/HPF page 36)



Pump model EM-T SP - only for ATEX zone 2
(See pump model HTT- SP page 30)



Pump model EM-CO - only for ATEX zone 2
(See pump model HCO page 42)





MECHANICAL SEAL CENTRIFUGAL PUMPS

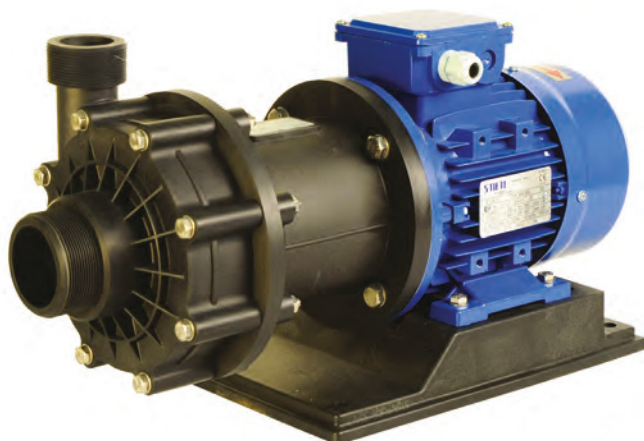

STANDARD

- Gas threaded in and out connections.
- Direct starting motor.

OPTIONAL

- Flanges available (DIN or ANSI).
- Dry-running protection device.
- Baseplate (from HCO 95 to HCO 140).
- Available in ATEX version for zone 2 II3G (pump mod. EM-CO).

MAIN FEATURES

Centrifugal pumps series HCO with mechanical seal are made of thermoplastic materials (Polypropylene and PVDF) and are suitable for high corrosive liquids containing solids in suspension. The seal of pumps HCO size 95-10 is guaranteed by a special elastomeric lip seal, while all the other pump sizes (from size 110 to 170) are equipped with an internal PTFE bellows mechanical seal (sic/ceramic), which is manufactured by GemmeCotti.

- Materials available: PP / PVDF.
- Flow up to 130 m³/h; Head up to 48 m.
- Temperature: PP: max 70° C - PVDF: max 90° C.
- Max viscosity: 200 cSt.
- Pressure rating: NP 6 at 20° C.
- Lip seal for pumps size 95-10; internal PTFE bellows mechanical seal for all the other sizes.
- Suitable for high corrosive liquids containing solids in suspension (non-abrasive solids - max. 5% - dimension max. 3 mm).

PERFORMANCE CURVES 50HZ - 2900 RPM

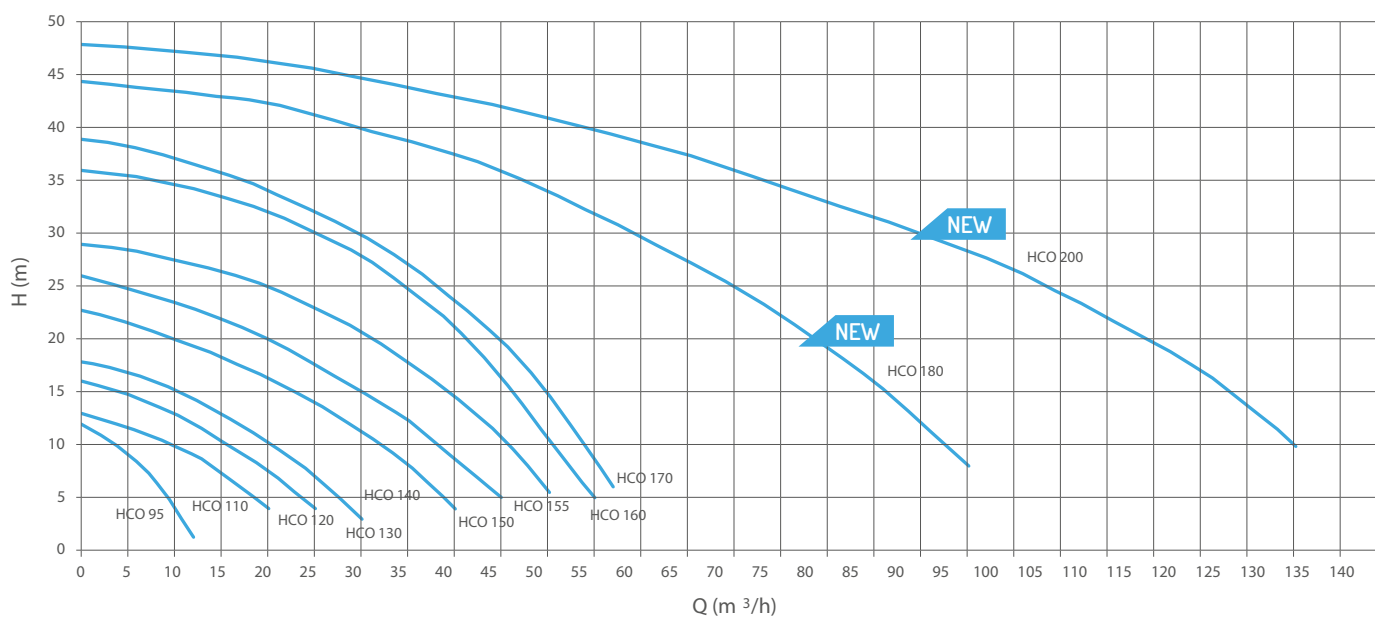

HCO TECHNICAL DATA

PUMP SIZE	MATERIAL	Ø MAX		H MAX		SUCTION CONNECTION	DISCHARGE CONNECTION	PUMP WEIGHT (kg)		SUITABLE MOTOR POWER (KW) - 2900 rpm	MOTOR FLANGE AND FRAME
		50HZ (m³/h)	60HZ (usgpm)	50HZ (mcl)	60HZ (ft)			PP	PVDF		
HCO 95-10	PP- PVDF	12	52	12	47	1 1/2" FEMALE	1" MALE	10	12	0,55	71 - B3/B5
HCO 110	PP- PVDF	20	88	13	59	2 1/2" MALE	2" MALE	10	12	1,1	80B - B3/B5
HCO 120	PP- PVDF	25	100	16	75	2 1/2" MALE	2" MALE	10	12	1,5 - 2,2	90S - 90L - B3/B5
HCO 130	PP- PVDF	30	158	18	90	2 1/2" MALE	2" MALE	10	12	2,2	90L - B3/B5
HCO 140	PP- PVDF	40	212	22	104	2 1/2" MALE	2" MALE	11	13	3-4	100L - 112M - B3/B5

HCO 95/10 - 110 - 120 - 130 - 140 PP/PVDF DIMENSIONS

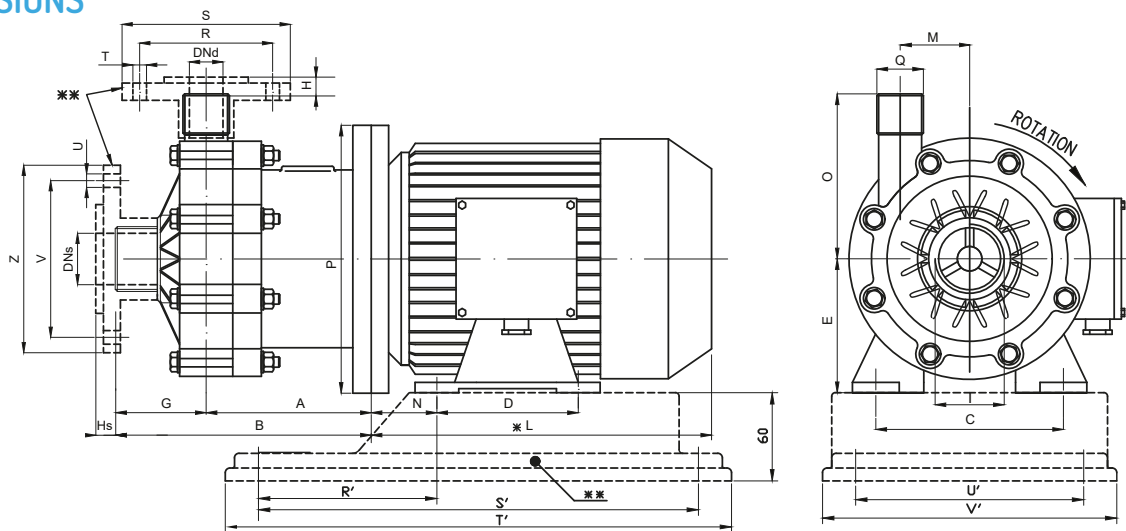

PUMP TYPE	FLANGES DIMENSIONS - mm -							
	R	S	T	U	V	Z	DN _s	DN _d
HCO 95-10	85	115	14	18	110	150	40	25
HCO 110 - 120 - 130 - 140	125	168	18	18	145	188	65	50

PUMP TYPE	BASEPLATE DIMENSIONS - mm -				
	R'	S'	T'	U'	V'
HCO 95-10	112	244	280	130	160
HCO 110 - 120 - 130	120	302	350	157	205
HCO 140	140	352	400	202	250

PUMP TYPE	MOTOR FLANGE B3 - B5	Kw	DIMENSIONS - mm -														
			A	B	C	D	E	G	H _s	H	I	- L	M	N	O	P	Ø
HCO 95-10	71 B	0,55	110	180	112	90	71	70	20	9	1 1/2" FEMALE	215	45	45	100	160	1" MALE
HCO 110	80 B	1,1	199	290	125	100	80	91	10	13	2 1/2" MALE	232	66	50	140	200	2" MALE
HCO 120	90 S	1,5	209	290	140	100	90	91	10	13	2 1/2" MALE	262	66	56	140	200	2" MALE
HCO 120	90 L	2,2	209	290	140	125	90	91	10	13	2 1/2" MALE	287	66	56	140	200	2" MALE
HCO 130	90 L	2,2	209	290	140	125	90	91	10	13	2 1/2" MALE	280	66	56	140	200	2" MALE
HCO 140	100 L	3	219	310	160	140	100	91	10	13	2 1/2" MALE	315	66	63	140	250	2" MALE
HCO 140	112 M	4	219	310	190	140	112	91	10	13	2 1/2" MALE	325	66	70	140	250	2" MALE

OPTIONAL UPON REQUEST: Baseplate (from HCO 95 to HCO 140) - Flanges.
 NOTE: DIRECTION OF ROTATION IS COUNTER CLOCKWISE AS SEEN WHEN FACING THE MOTOR.
 PUMPS AVAILABLE THREADED OR FLANGED.

HCO TECHNICAL DATA

PUMP SIZE	MATERIAL	Q MAX		H MAX		SUCTION CONNECTION	DISCHARGE CONNECTION	PUMP WEIGHT (kg)		SUITABLE MOTOR POWER (KW) - 2900 rpm	MOTOR FLANGE AND FRAME
		50HZ (m³/h)	60HZ (usgpm)	50HZ (mcl)	60HZ (ft)			PP	PVDF		
HCO 150	PP- PVDF	45	242	26	124	3" MALE	2 1/2" MALE	11	13	5,5 - 7,5 - 9,2	132 S - B3/B5
HCO 155	PP- PVDF	50	265	29	140	3" MALE	2 1/2" MALE	11	13	5,5 - 7,5 - 9,2	132 S - B3/B5
HCO 160	PP- PVDF	55	290	36	170	3" MALE	2 1/2" MALE	11	13	7,5 - 9,2	132 M - B3/B5
HCO 170	PP- PVDF	58	300	38	175	3" MALE	2 1/2" MALE	11	13	7,5 - 9,2	132 M - B3/B5

HCO 150 - 155 - 160 - 170 PP/PVDF DIMENSIONS

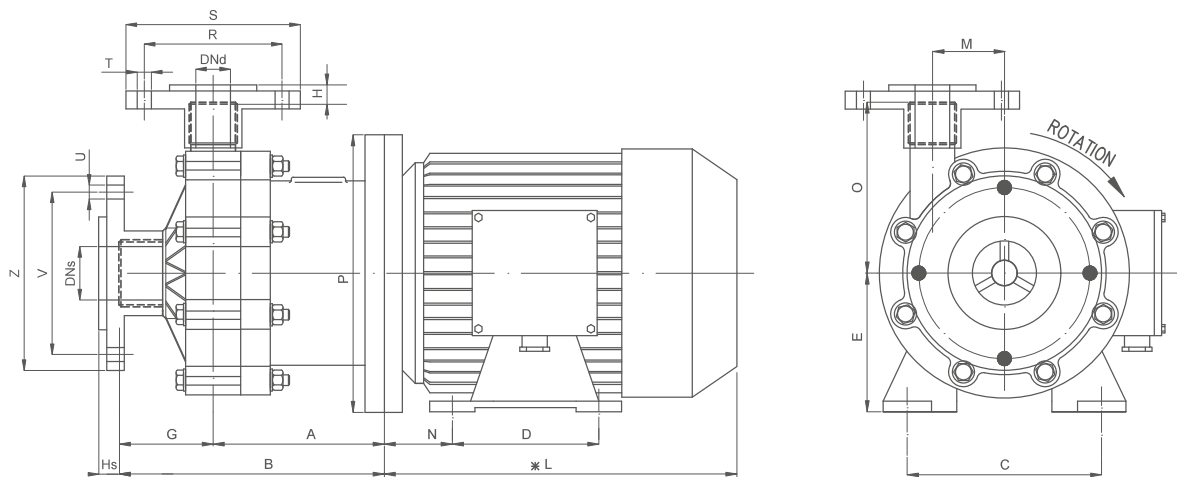

PUMP TYPE	FLANGES DIMENSIONS - mm -							
	R	S	T	U	V	Z	DNs	DNd
HCO 150 - 155 - 160 - 170	145	188	18	18	160	203	80	65

PUMP TYPE	MOTOR FLANGE B3 - B5	KW	DIMENSIONS - mm -														
			A	B	C	D	E	G	Hs	H	I	- L	M	N	O	P	Q
HCO 150 - HCO 155	132 SA - SB	5,5	184	275	216	140	132	91	10	10	3" MALE	380	82,5	89	170	300	2" 1/2 MALE
HCO 150 - HCO 155	132 SA - SB	7,5	184	275	216	140	132	91	10	10	3" MALE	380	82,5	89	170	300	2" 1/2 MALE
HCO 150 - HCO 155	132 MA	9,2	184	275	216	178	132	91	10	10	3" MALE	418	82,5	89	170	300	2" 1/2 MALE
HCO 160 - HCO 170	132 SB	7,5	184	275	216	140	132	91	10	10	3" MALE	380	82,5	89	170	300	2" 1/2 MALE
HCO 160 - HCO 170	132 MA	9,2	184	275	216	178	132	91	10	10	3" MALE	418	82,5	89	170	300	2" 1/2 MALE

OPTIONAL UPON REQUEST: Flanges.
 NOTE: DIRECTION OF ROTATION IS COUNTER CLOCKWISE AS SEEN WHEN FACING THE MOTOR.
 PUMPS AVAILABLE THREADED OR FLANGED.

HCO TECHNICAL DATA

PUMP SIZE	MATERIAL	Ø MAX		H MAX		SUCTION CONNECTION	DISCHARGE CONNECTION	PUMP WEIGHT (kg)		SUITABLE MOTOR POWER (KW) 2900 rpm	MOTOR FLANGE AND FRAME
		50HZ (m³/h)	60HZ (usgpm)	50HZ (mcl)	60HZ (ft)			PP	PVDF		
HCO 180	PP- PVDF	95	502	44	208	3 1/2" MALE	2 1/2" MALE	13	15	11 - 15 - 18,5	160M2 - 160L2 - B5
HCO 200	PP- PVDF	130	687	48	227	4" MALE	3 1/2" MALE	13	15	15 - 18,5 - 22 - 37	160M2 - 160L2 - 180M2 200L2 - B5

HCO 180 - 200 PP/PVDF DIMENSIONS

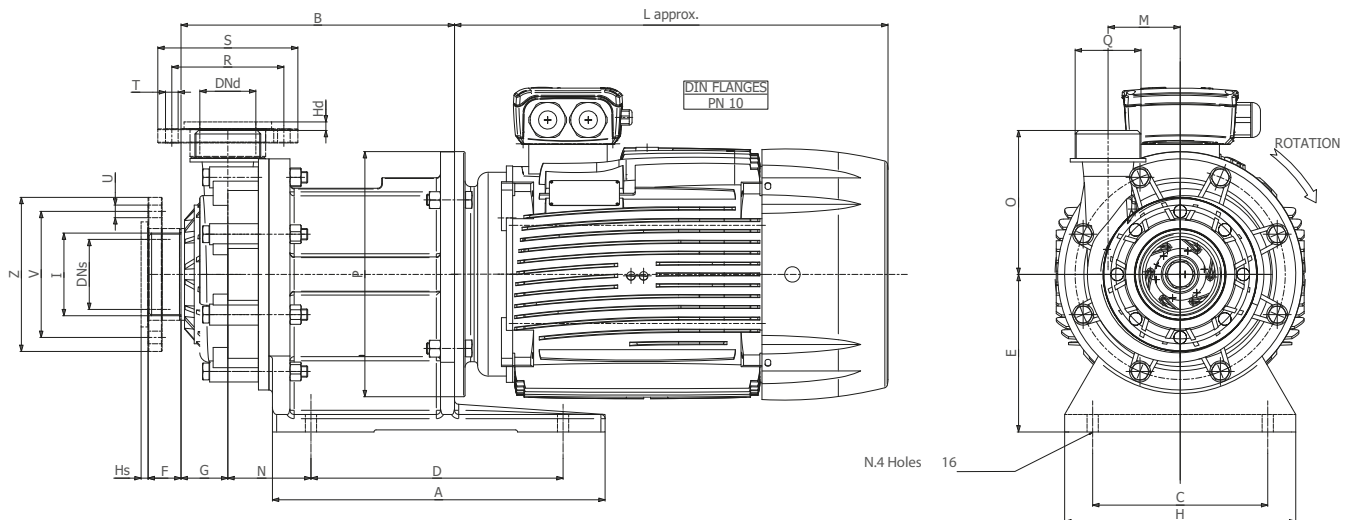

PUMP TYPE	FLANGES DIMENSIONS - mm -							
	R	S	T	U	V	Z	DNs	DNd
HCO 180	145	185	18	18	160	200	80	65
HCO 200	160	200	18	18	180	220	100	80

PUMP TYPE	MOTOR FLANGE B5	P (kW)	DIMENSIONS - mm -																
			A	B	C	D	E	F	G	H	Hs	Hd	I	L*	M	N	O	P	Q
HCO 180	160 M2	11	475	393,5	250	360	225	43,5	70	330	12	10	3-1/2" MALE	520	103	118,5	205,5	350	2-1/2" MALE
HCO 180	160 M2	15	475	393,5	250	360	225	43,5	70	330	12	10	3-1/2" MALE	520	103	118,5	205,5	350	2-1/2" MALE
HCO 180	160 L2	18,5	475	393,5	250	360	225	43,5	70	330	12	10	3-1/2" MALE	560	103	118,5	205,5	350	2-1/2" MALE
HCO 200	160 M2	15	475	390	250	360	225	47	66,5	330	10	12	4" MALE	520	103	118,5	205,5	350	3-1/2" MALE
HCO 200	160 L2	18,5	475	390	250	360	225	47	66,5	330	10	12	4" MALE	560	103	118,5	205,5	350	3-1/2" MALE
HCO 200	180 M2	22	475	390	250	360	225	47	66,5	330	10	12	4" MALE	620	103	118,5	205,5	350	3-1/2" MALE
HCO 200	200 L2	37	475	390	250	360	225	47	66,5	330	10	12	4" MALE	680	103	118,5	205,5	400	3-1/2" MALE

* Approximation.

OPTIONAL UPON REQUEST: Flanges.
 NOTE: DIRECTION OF ROTATION IS COUNTER CLOCKWISE AS SEEN WHEN FACING THE MOTOR.
 PUMPS AVAILABLE THREADED OR FLANGED.



GEMMECOTTI SRL

Via A. Volta 85/A
20816 Ceriano Laghetto MB
ITALY
EUROPEAN UNION

Ph: +39 02.96460406

Fax: +39 02.96469114

info@gemmecotti.com
www.gemmecotti.com

