

APPLICATION

Usage général : fabrication de pâte à papier, eau, traitement d'eau, eaux usées, produits chimiques poudreux et cristallisants, vinicole, cimenterie, transport pneumatique, stockage.
/ *General services : Pulp&paper, used water, fiber, powder and particles, solid containing liquid, Under-silo application.*

CARACTERISTIQUES GENERALES / General Characteristics

Unidirectionnelle ou bidirectionnel. / *Unidirectional or birectional application*
Fonction ouverture/fermeture ou de réglage. / *ON/OFF or regulating.*
Montage entre-brides ISO PN10. *Wafer PN10*
Zéro fuite grâce au siège élastomère. / *Zero leakage with elastomer seat*
Matériaux du siège interchangeables. / *Interchangeable seat materials (NBR/EPDM/FKM/PTFE)*
Corps *Body* : GG25, GGG40, WCB, CF8, CF8M, SS316L. / *Other materials upon request*
Tous types d'actionneurs : manuel, levier, réducteur, pneumatique DA ou SA, électrique, hydraulique.
/ *All kinds of actuators possible*

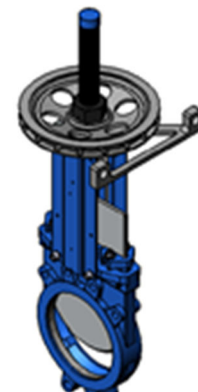

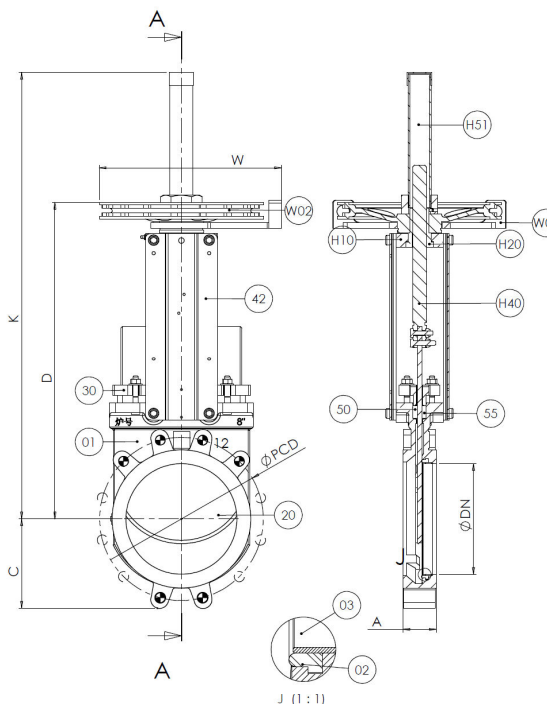

W02	CHAIN WHEEL	CAST IRON	CAST IRON
W01	CHAIN SUPPORT	CAST IRON	CAST IRON
H51	TUBE	ACIER/Steel	ACIER/Steel
H20	ECROU BRONZE / BRONZE NUT	BRONZE	BRONZE
H40	TIGE / STEM	SS304	SS304
H10	POTENCE YORK	ACIER/Steel	ACIER/Steel
55	TRESSE PACKING	PTFE	PTFE
50	TORE / O-RING	NBR	EPDM
03	FRETTE / RETAINER	SS304	SS316
42	SUPPORT	ACIER/Steel	ACIER/Steel
02	SIEGE / SEAT	NBR	EPDM
30	FOULOIR / GLAND	DI	CF8M
20	PELLE / GATE	SS304	SS316
01	CORPS / BODY	GG25	CF8M
N°	DESIGNATION	KG01W10H-14N	KG01W10H-66E



CONDITIONS DE SERVICE :

Service Pressure	Seat température
DN50-200 : 10 bar	NBR : -10°C / +90°C
DN250 : 8 bar	EPDM : -20°C / +120°C
DN300 : 6 bar	VITON : -10°C / +180°C
DN350-400 : 4 bar	PTFE : -196°C / +180°C
DN450-600 : 3 bar	
DN700-1200 : 2 bar	

DN	A	B	C	D	F	W	K	ØPCD			prof.	Weight (kg)
50	40	92	63	289	124	210	410	125	4xM16	0	8	7
65	40	92	70	316	139	210	440	145	4xM16	0	8	8
80	50	92	92	342	154	210	460	160	4xM16	4	10	9
100	50	92	105	382	174	210	500	180	4xM16	4	10	10
125	50	102	120	415	192	210	585	210	4xM16	4	10	13
150	60	102	130	458	217	210	637	240	4xM20	4	12	16
200	60	120	160	575	270	300	815	295	4xM20	4	12	28
250	70	120	198	676	326	300	1016	350	6xM20	6	15	42
300	70	120	234	776	380	300	1116	400	6xM20	6	15	56
350	96	290	256	906	438	500	1336	460	10xM20	6	19	108
400	100	290	292	1012	493	500	1442	515	10xM24	6	20	130
450	106	290	308	1098	546	500	1628	565	14xM24	6	24	166
500	110	290	340	1210	620	500	1740	620	14xM24	6	24	203
600	110	290	400	1416	714	500	2046	725	14xM27	6	24	293
700	110	400	470	1650	830	800	2290	840	16xM27	8	20	440
750	110	434	488	1740	900	800	2485	914.4	16xM30	12	20	498
800	110	400	505	1830	970	800	2680	950	16xM30	8	20	570
900	110	400	555	2075	1040	800	3020	1050	20xM30	8	20	740
1000	110	450	610	2260	1152	800	3400	1160	20xM33	8	20	920
1200	150	450	725	2460	1255	800	3980	1380	20xM36	12	30	1350



Standard seat



Reinforced seat



Standard seat



Bidirectional seat
KG21