

2" Non-Metallic Models

EXP SERIES PUMPS

ARO® EXP 2" non-metallic pumps achieve flow rates of up to 184 GPM (696.4 LPM) and offer a wide array of material and porting configurations. 2" non-metallic pumps are often used for transfer, filling, recirculation and batching in Chemical, Industrial and Water/Waste-water treatment markets.

UPGRADE
PUMP FOR REMOTE
ACTUATION CAPABILITY

Ratio:	1:1
Maximum GPM (LPM):	184 (696)
Displacement per cycle Gallons (Liters):	1.4 (5.3)
Air Inlet (Female):	3/4 - 14 N.P.T.
Fluid Inlet/Outlet:	2" ANSI/DIN hybrid flange (side or center)
Max. operating pressure psi (bar):	120 (8.3)
Suspended solids max. dia. in. (mm):	1/4" (6.4)
Weight lbs (kg):	Polypropylene, Side Ported 85.3 (38.7) Polypropylene, Center Ported 89.0 (40.4) PVDF, Side Ported 110.9 (50.3) PVDF, Center Ported 116.8 (53)
Maximum dry suction lift ft (m):	19.5 (5.9)
Sound Level:	70 PSI 60 Cycles/Min 85.0 db(A)
Muffler Included:	93139



Ordering

Position	1	2		3	4	5		6	7	8		9	10	11
Example:	PX20	X	-	X	X	S	-	X	X	X	-	A	X	X

Position 1 Model Series	Position 2 Center Section	Position 3 Connections	Position 4 Wetted Parts	Position 5 Hardware	Position 6 Seat Material	Position 7 Ball Material	Position 8 Diaphragm Material	Position 9
PD20 - Standard Pump PE20 - Electronic Interface Accessible Pump	E - Conductive Polypropylene P - Polypropylene	F - 2" ANSI/DIN Hybrid Side Flange Y - 2" ANSI/DIN Hybrid Center Flange	E - Conductive Polypropylene* K - PVDF N - Conductive PVDF* P - Polypropylene	S - SS	K - PVDF P - Polypropylene	A - Santoprene® C - Hytrel® G - Nitrile T - PTFE V - Viton®	A - Santoprene® C - Hytrel® G - Buna- N L - Long-Life PTFE T - PTFE/ Santoprene® V - Viton®	Revision Level Position 10 & 11 Specialty Code Fluid control options for pump with electronic interface (PE20 model). See complete description on next page

* Acceptable for use in hazardous locations. - NEC / CEC: Class I&II, Div 1&2, Group A-D
- ATEX: Zone 1&2, 21&22

Hytrel® is a registered trademark of DuPont company, Santoprene® is registered trademark of Monsanto and Viton® is a registered trademark of ExxonMobil

Accessories

Air Line Connection Kit | 66109

(Piggyback Filter/Regulator with gauge, pipe nipple and 5-foot air hose)

Diaphragm Failure Detection | Kit No.67237

Service Repair Kits | 637369 (air motor for PD20P), **637373-XXX** (fluid section with seats), **637374-X** (major air valve assembly)

Flange Connection Kit | 67341-E20N

2" Non-Metallic Dimensions and Flow Charts

PX20P-FXS-XXX-AXXX, PX20E-FXS-XXX-AXXX

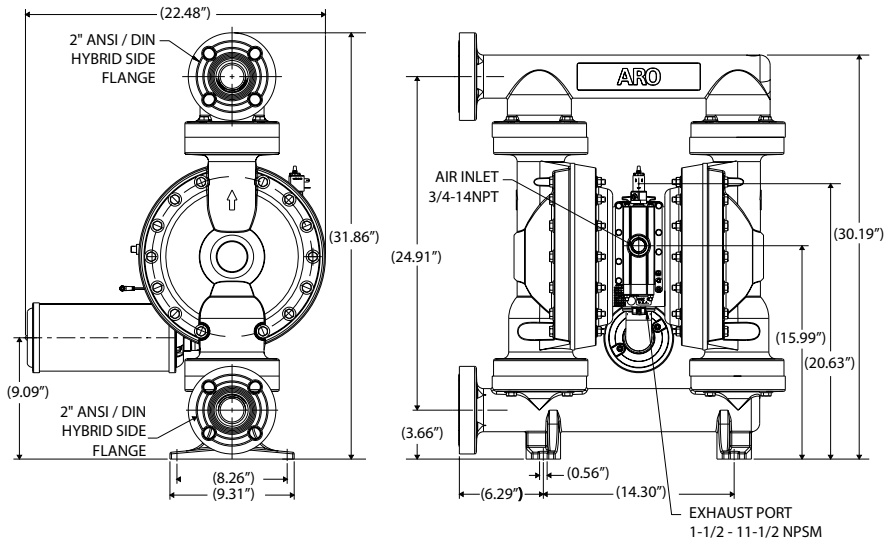

PX20P-YXS-XXX-AXXX

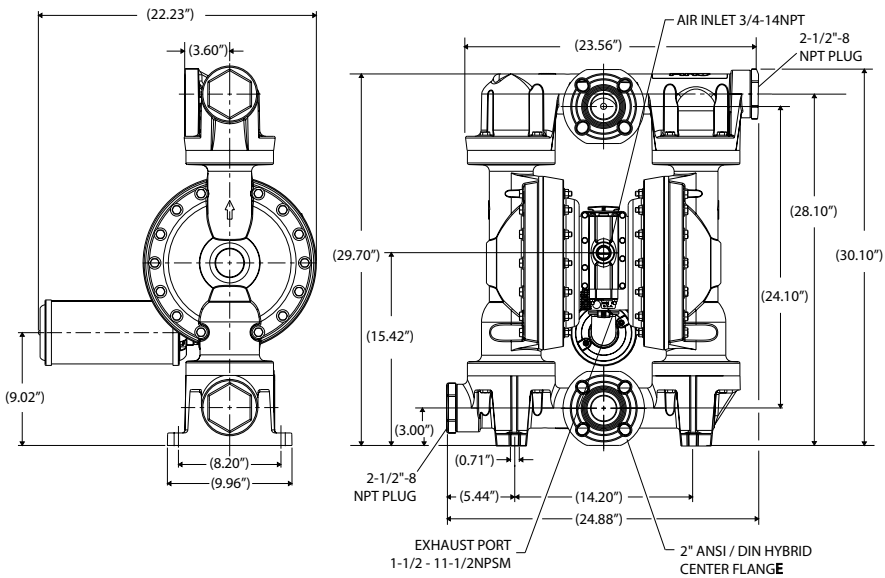

Ordering Position 10 Specialty Code 1 (Blank if no Specialty Code)

- A - Solenoid 120VAC
- B - Solenoid 12VDC
- C - Solenoid 240VAC
- D - Solenoid 24VDC
- E - 12vDC NEC/CEC*
- F - 24vDC NEC/CEC*
- G - Solenoid 12VDC ATEX/IECex*
- H - Solenoid 24VDC ATEX/IECex*
- J - 120VAC NEC/CEC*
- K - Solenoid 220VAC ATEX/IECex*
- N - Solenoid with no coil
- O - Standard Valve Block (No Solenoid)
- P - Ported Motor (No major valve provided)

Ordering Position 11 Specialty Code 2 (Blank if no Specialty Code)

- E - End of stroke feedback + Leak Detection
- F - End of stroke feedback
- G - End of Stroke ATEX/IECex*
- H - End of Stroke/Leak Detection ATEX/IECex*
- L - Leak Detection
- M - Leak Detection ATEX/IECex/NEC/CEC*
- O - No Option
- R - End of Stroke Feedback NEC / CEC*
- T - End of Stroke Feedback + Leak Detection NEC / CEC*

* Acceptable for use in hazardous locations.
- NEC / CEC: Class I&II, Div 1&2, Group A-D
- ATEX: Zone 1&2, 21&22

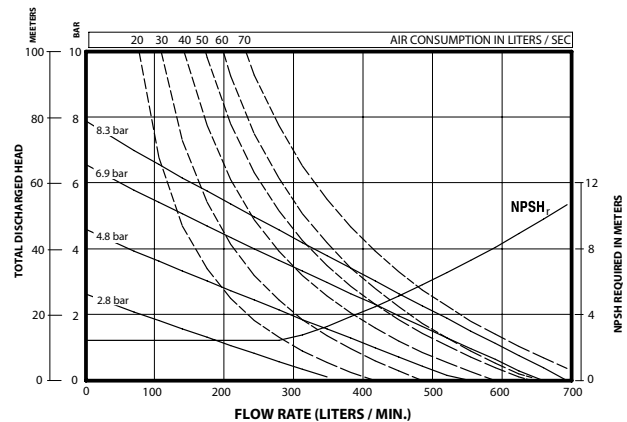
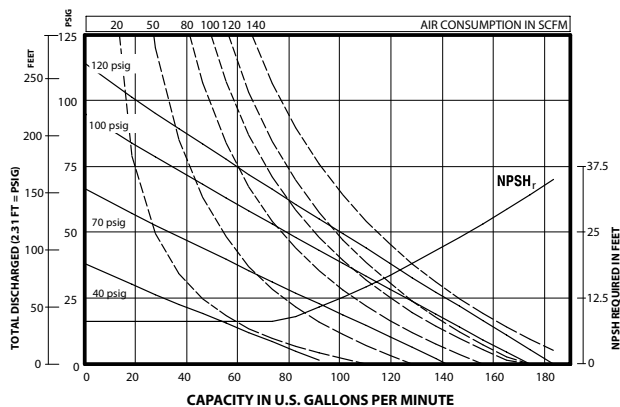

Performance based on an elastomeric fitted pump (PX20P-FXS-XXX), flooded suction with water at ambient conditions.
Due to varying materials of construction, assembly configurations and operating conditions, published data is for reference only