

FOR REFERENCE ONLY

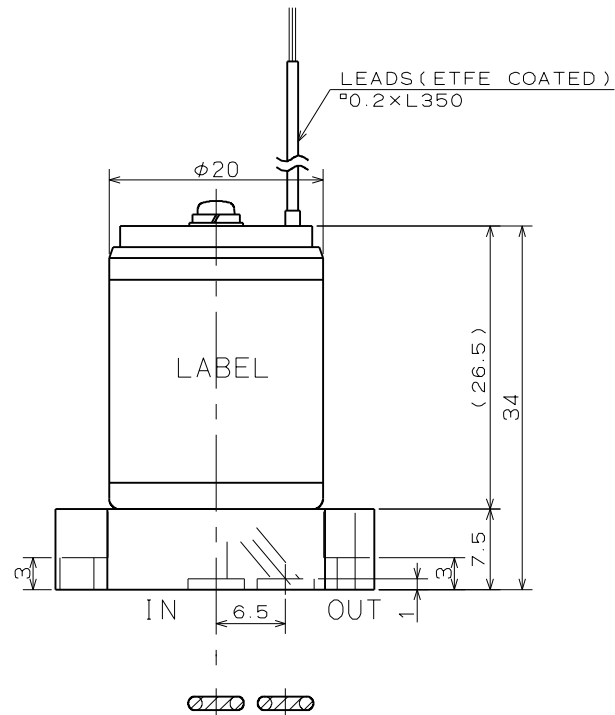

SOLENOID VALVE

SPECIFICATIONS for MODEL STV-02K-MFG

- ORIFICE DIAMETER : 1.2mm
- PORT CONNECTION : O-RING SEAL
- OPERATING PRESSURE RANGE : IN -50 ~ 200kPa
{-375mmHg ~ 2bar}
- OUT 0 ~ 50kPa
{0 ~ 0.5bar}
- FLUID MEDIA : FLUIDS CHEMICALLY COMPATIBLE WITH MATERIALS BELOW
- MEDIA TEMPERATURE RANGE : 5 ~ 50°C
- AMBIENT TEMPERATURE RANGE : 5 ~ 50°C
- RATED VOLTAGE : 12VDC, 24VDC
- POWER CONSUMPTION : 2.5W
- DUTY CYCLE : CONTINUOUS
- COIL TEMPERATURE INCREASE : MAX. 80°C FROM ROOM TEMPERATURE
- INSULATION CLASS : CLASS B
- DIELECTRIC STRENGTH : 1500VAC FOR 60s

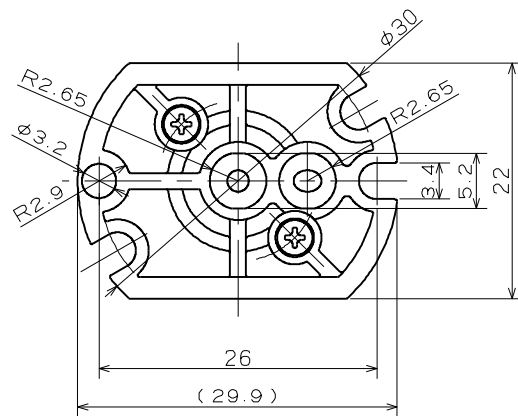

WETTED MATERIALS

DIAPHRAGM	PTFE	1	
SOFT SEAL	DAIEL PERFLUOR	1	
VALVE BODY	PEEK	1	
O-RING	DAIEL PERFLUOR	2	φ2.6×W1.3
PART NAME	MATERIAL	REQD.	NOTE

SOLENOID VALVE

STV-02K-MFG