

s.24 DZR full port 1/2"-2" dezincification-resistant hot forged ball valves



Several governmental authorities recommend use of special alloys for valves handling water in areas where there is a problem of dezincification. RuB CR valves are designed to meet such requirements.

Through the use of new technology these valves retain the reliability and competitiveness of brass, but are comparable to bronze in corrosion resistance.

Be kind with yourself, make sure the valve that brings you pure fresh water is an RuB CR valve.

Features and Specifications:

- Hot forged sand blasted DZR unplated body and cap sealed with Loctite or equivalent thread sealant
- Valve design and construction approved by Swedcert (S), Sintef-Byggforsk (N), VTT (SF), WRAS (UK), GOST-R (RU), Hygenic (RU), ROSTEKHNADZOR (RU), UkrSepro (U)
- Dezincification Resistant ADZ-T and ADZ-P brass approved to SBN-PFS 1983:2 and NR-BFS 1988:18 specifications
- Full port to DIN 3357 for maximum flow
- 24h 100% seal test guaranteed
- Pure PTFE self-lubricating seats with flexible-lip design
- Dual sealing system allows valve to be operated in either direction making installation easier
- Chrome plated DZR brass ball for longer life
- No metal-to-metal moving parts
- Blowout-proof unplated DZR brass stem
- Two EPDM O-rings at the stem for maximum safety
- No maintenance ever required
- Handle stops on body to avoid stresses at stem
- Handle removable with valve in service
- Geomet® carbon steel handle with thick PVC dip coating
- Handle clearly shows ball position
- EN 10226-1, ISO 228 parallel Female by Female threads
- Silicone-free lubricant on all seals
- 30 bar (Kg/cm²) non-shock cold working pressure
- Range: -40°C +150°C temperature (Warning: freezing of the fluid in the



Options:

- CW617N brass body and components
- Brass stem extension
- T-handle
- Oval lockable handle
- AISI 430 stainless steel handle
- Patented locking device

Upon request:

- AISI 316 stainless steel ball and/or stem
- Glass filled PTFE seals
- Custom design

Approved By:



NOTE: Approvals apply to specific configurations only.

The product described in this document meets the requirements of PED Directive 97/23 and according to art.3 par.3, it does not require CE marking:
it cannot be used with dangerous gases in sizes larger than 25mm;
it cannot be used with non-dangerous gases in sizes larger than 40mm.



RUB RUBINETTERIE UTENSILERIE BONOM



s.24 DZR

full port 1/2"-2"

dezincification-resistant hot forged ball valves



Technical Specifications:

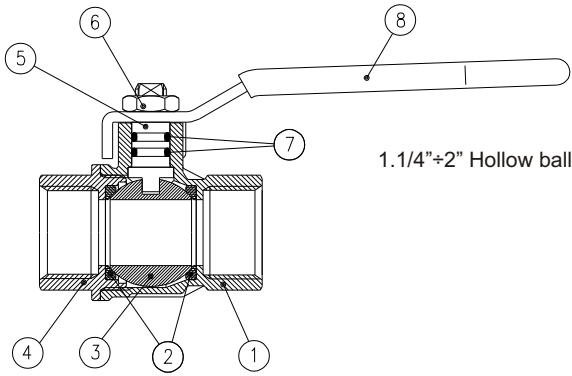

PART DESCRIPTION		Q.ty	Material
1	Unplated body	1	ADZ
2	Ball seat	2	Ptfe
3	Chrome plated ball	1	ADZ
4	Unplated end cap	1	ADZ
5	Unplated stem O-Ring design	1	ADZ
6	Geomet® nut	1	CB4FF
7	O-Ring	2	EPDM
8	White PVC coated geomet® steel handle	1	DD11

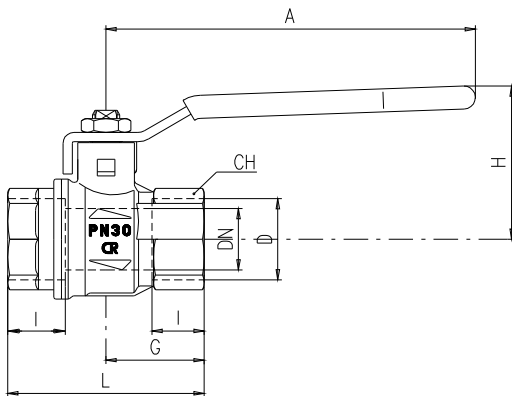

Code	S24D00	S24E00	S24F00	S24G00	S24H00	S24I00
D (inch)	1/2	3/4	1	1 1/4	1 1/2	2
DN(mm)	15	20	25	32	40	50
l (mm)	15.5	17	21	23	23	26.5
L (mm)	59	64	81	93	102	121
G (mm)	29.5	32	40.5	46.5	51	60.5
A (mm)	100	120	120	158	158	158
H (mm)	43	50	54	73	79	86
CH(mm)	25	31	40	49	54	68.5

DN shows the nominal flow diameter.
Actual flow diameter complies with full port DIN 3357 part 4.

Ask for additional information on the whole range of RuB valves and consult with your supplier for special applications.

Pressure - Temperature Chart

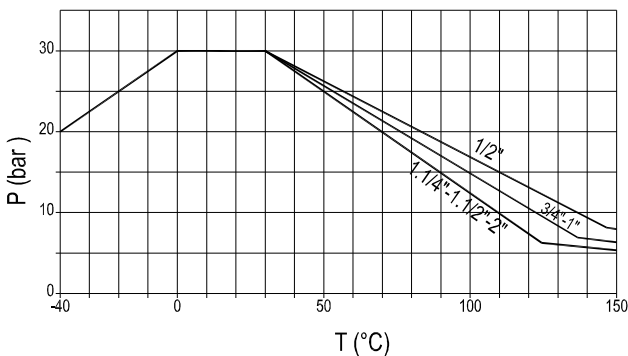

Pressure Drop Chart

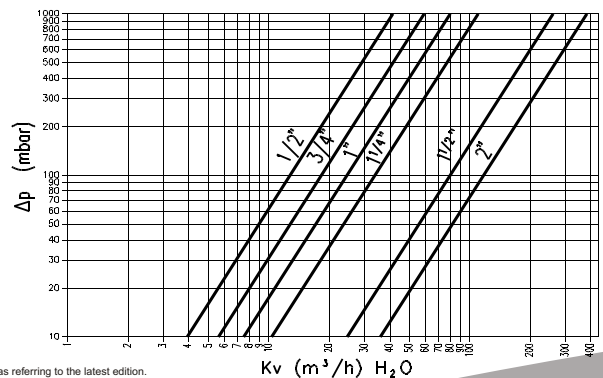

The company reserves all rights for the information contained herein. Products may be changed at any time without notice. Any undated reference to a code or standard shall be interpreted as referring to the latest edition. RuB and logo are registered trademark of RuB-Rubinetteria utensilerie Bonomi. Others logos are property of respective owners.

RUB RUBINETTERIE UTENSILERIE BONOMI

Via Padana Superiore 27/29 25080 Ciliverghe di Mazzano (Bs) Italy
Ph: +39 030 212441 - Fax: +39 030 2629498
sales@rubvalves.com - www.rubvalves.com

