

## ARTICULO: 2110

### Válvula de esfera paso total tipo Wafer Acero Inoxidable Stainless steel full port ball valve, Wafer Type

#### Características

1. Válvula esfera paso total tipo wafer.
2. Montaje entre bridas EN 1092 PN16.
3. Construcción en Ac. Inox. ASTM A182 F316.
4. Asientos y Juntas PTFE.
5. Presión de trabajo máxima 16 bar.
6. Temperatura de trabajo  $-20\text{ }^{\circ}\text{C} + 180\text{ }^{\circ}\text{C}$ .

#### Features

1. Full port ball valve, Wafer type.
2. Assembly between flanges EN 1092 PN16.
3. Made of Stainless Steel ASTM A182 F316.
4. Ball seats and Gasket PTFE.
5. Max. working pressure 16 bar.
- 6 Working Temperature  $-20\text{ }^{\circ}\text{C} + 180\text{ }^{\circ}\text{C}$ .

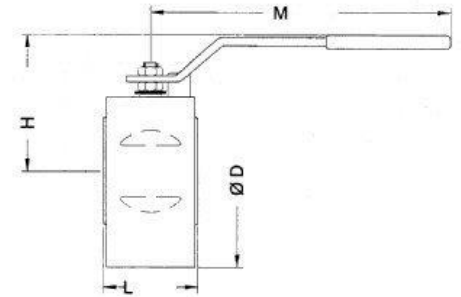
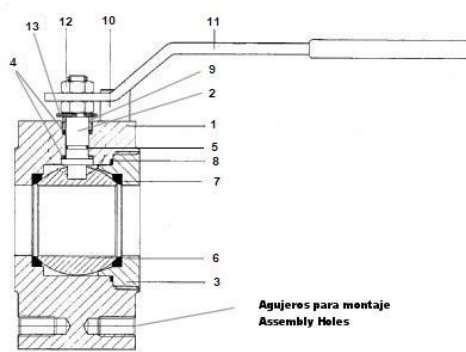

Nº	Denominación / Name	Material	Acabado Superficial/ Surface Treatment	Cód. Recambio / Spare Part Code
1	Cuerpo / Body	ASTM A182 F316	-----	-----
2*	Eje / Stem	ASTM A182 F316	-----	I2110
3	Tapón / Plug	ASTM A182 F316	-----	-----
4*	Arandela / Washer	PTFE	-----	2925
5*	Tórica / O'ring	FKM	-----	2925
6*	Bola / Ball	ASTM A182 F316	-----	2807
7*	Asiento / Ball Seat	PTFE	-----	2925
8*	Juntas / Gasket	PTFE	-----	2925
9	Prensa / Stem packing	AISI 304	-----	-----
10	Tope / Stopper	Acero / Steel	Cincado / Zinc Plated	-----
11	Maneta / Handle	Acero / Steel	Cincado / Zinc Plated	-----
12	Tuerca / Nut	Acero / Steel	Cincado / Zinc Plated	-----
13	Arandela Resorte / Spring Washer	Acero / Steel for Springs	Cincado / Zinc Plated	-----

\* Piezas de recambio disponibles / Available spare parts

## DIMENSIONES GENERALES / GENERAL DIMENSIONS

Ref.	Medida / Size	PN	Agujeros Montaje / Assembly Holes	Dimensiones / Dimensions (mm)				Peso / Weight (Kg)
				ØD	H	L	M	
2110 04	1/2"	16	4 x M12	88	90	32	130	1.40
2110 05	3/4"	16	4 x M12	98	90	42	180	2.20
2110 06	1"	16	4 x M12	108	90	45	180	2.75
2110 07	1 ¼"	16	4 x M16	128	110	54	270	4.64
2110 08	1 ½"	16	4 x M16	138	110	65	280	6.35
2110 09	2"	16	4 x M16	148	125	72	280	7.90
2110 10	2 ½"	16	4 x M16	175	150	98	360	13.90
2110 11	3"	16	8 x M16	188	160	118	360	20.90
2110 12	4"	16	8 x M16	210	180	140	470	31.30

## CURVA PRESION TEMPERATURA / PRESSURE TEMPERATURE RATING

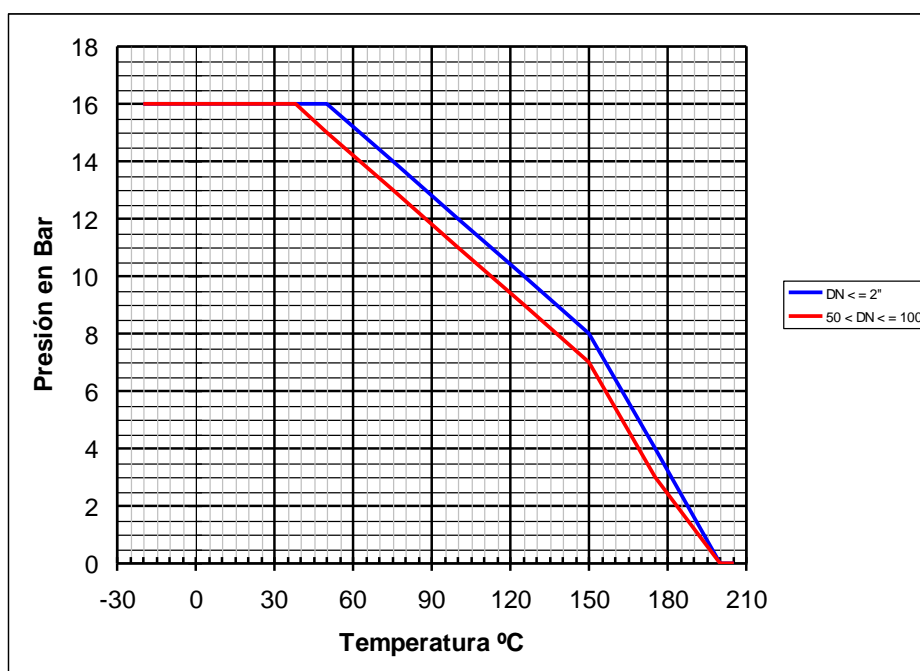

## VALORES DE Kv / Kv VALUES

Kv = Es la cantidad de metros cúbicos por hora (m<sup>3</sup>/h) que pasará a través de la válvula generando una pérdida de carga de 1 bar.

Kv = Flow rate of water in cubic meter per hour (m<sup>3</sup>/h) that will generate a pressure drop of 1 bar across the valve.

1/2"	3/4"	1"	1 ¼"	1 ½"	2"	2 ½"	3"	4"
24	43	83	130	205	340	520	1100	1820